

17 861 875



- 146mm projection
- rigid, thermally insulated spout
- laminar flow
- height of mixer 288 mm
- height up to laminar flow regulator 180 mm
- hole diameter 35 mm
- provides filtered, hot water up to 93°C
- provides filtered, cold water
- max. flow 2 l/min at 3 bar flow pressure
- ready-to-use control unit for wall mounting (137mm x 159mm x 60mm)
- electronic magnetic valve
- 100-230 V, 50-60 Hz, 18 W power supply unit, incl. country-specific adapter set
- lead-free
- one lever for cold and hot water
- Spout ring cannot be removed.
- This product can help a building meet the requirements of Green Building Rating Systems, e.g. LEED®, BREEAM®, DGNB

NOTE: Not compatible with Reverse Osmosis

A minimum flow pressure of 3 bar is necessary for the HOT & COLD WATER DISPENSER to work perfectly in conjunction with a hot water tank and filter.

In addition, the installation must be above a kitchen sink.

The filter cartridge must be changed every six months. The installation instructions contain further information for guidance.

Detailed planning information and technical data can be found at www.dornbracht.com/professional

	Brushed Dark Platinum	17 861 875-99
	Chrome	17 861 875-00
	Brushed Platinum	17 861 875-06
	Platinum	17 861 875-08
	Durabronze (23kt Gold)	17 861 875-09
	Dark Chrome	17 861 875-19
	Brushed Durabronze (23kt Gold)	17 861 875-28
	Matte Black	17 861 875-33
	Brushed Champagne (22kt Gold)	17 861 875-46
	Champagne (22kt Gold)	17 861 875-47
	Brushed Chrome	17 861 875-93

17 861 875

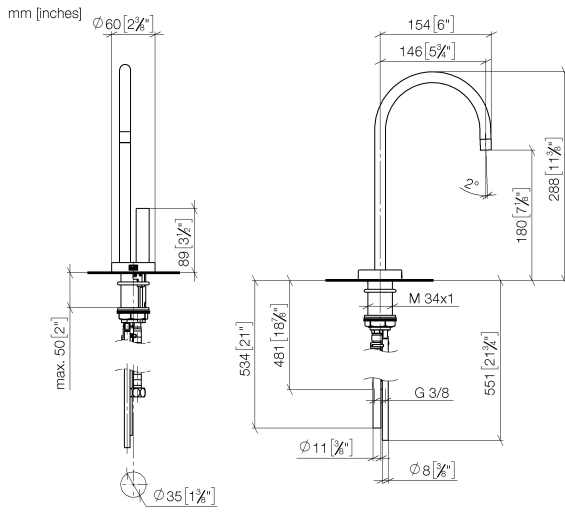

Flow rate chart

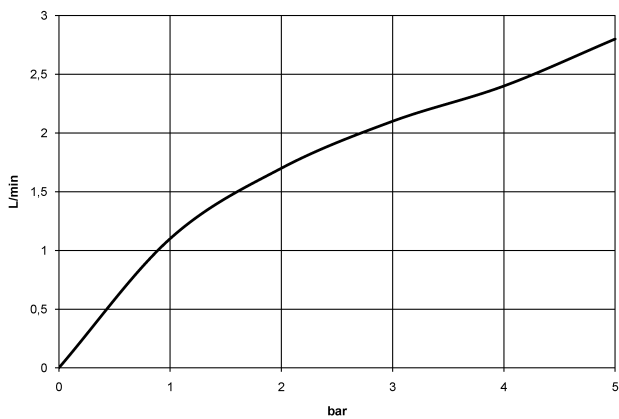

Codes & Standards

ADA	ASME A112.18.1	ASME A112.18.1/CSA B125.1	California Energy Commission (CEC)
cUPC	DIN 4109	Executive Order no. 1007	ISO 3822
NSF/ANSI 372	NSF/ANSI/CAN 61	NSF372	NSF61

Ü-Zeichen



TARA ULTRA HOT & COLD WATER DISPENSER - Brushed Dark Platinum

TARA ULTRA

17 861 875

Certificates

GDV_0400

IAPMO_4976

IAPMO_N-4

LGA_28

IAPMO_6

17 861 875

Product version from 4/1/2014 to 5/27/2021

Product version from 5/27/2021 to 5/28/2022

Product version from 5/28/2022

Parts for other
finishes can be found
here: [Chrome](#)

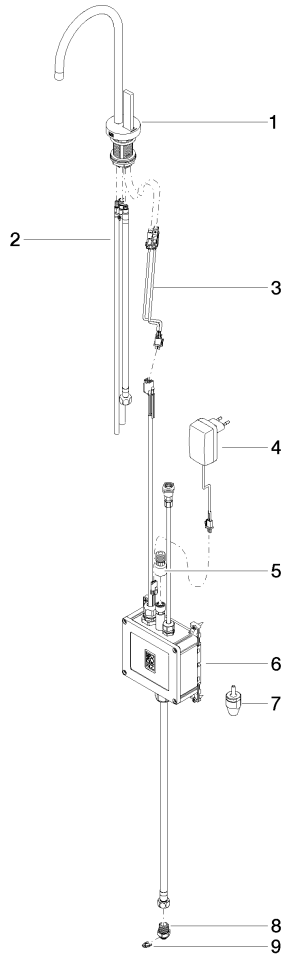



TARA ULTRA HOT & COLD WATER DISPENSER - Brushed Dark Platinum

TARA ULTRA

17 861 875

Spare parts list

Product version from 4/1/2014 to 5/27/2021

Product version from 5/27/2021 to 5/28/2022

Product version from 5/28/2022

No.	Item Number	Name	Quantity used	Delivery time
	90 17 85 100 05-99	fitting	9	30