

36 200 740



- Drehumstellung
- ohne Rosette
- Griff Ø 60 mm

Passt zu: CL.1, META, CYO

	Platin gebürstet	36 200 740-06
	Chrom	36 200 740-00
	Light Gold	36 200 740-26
	Light Gold gebürstet	36 200 740-27
	Messing gebürstet (23kt Gold)	36 200 740-28
	Schwarz matt	36 200 740-33
	Bronze gebürstet	36 200 740-42
	Champagne gebürstet (22kt Gold)	36 200 740-46
	Champagne (22kt Gold)	36 200 740-47
	Dark Platinum gebürstet	36 200 740-99

Benötigtes Zubehör



- UP-Zweiwege-Umstellung -** 35 202 970 90
- Max. Einbautiefe 160 mm
 - Min. Einbautiefe 85 mm

36 200 740

mm [inches]



Durchflussdiagramm



Zertifikate

LGA_38379.

WRAS_2307045.

36 200 740

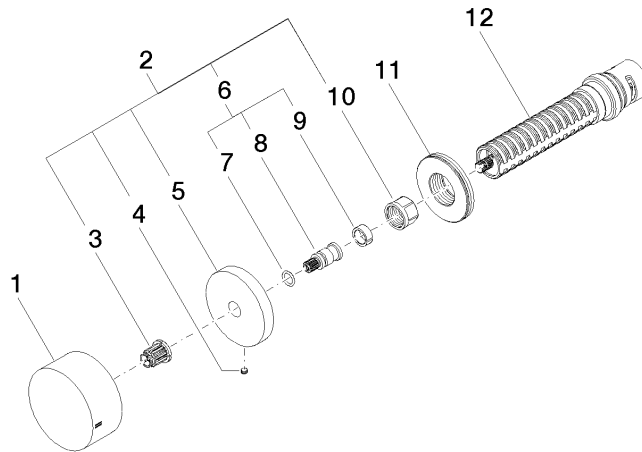

Ersatzteilstückliste

Nr.	Artikelnummer	Benennung	Verbaumenge	Lieferzeit
1	09 20 74 044-06	Griff	1	60
2	04 27 74 004 00-06	Rosette	1	10
3	90 12 12 002 00 90	Rastbuchse	1	2
4	09 31 11 055 90	Stift	1	2
5	09 27 74 004-06	Rosette	1	10
6	04 29 06 020 00-00	Spindel	1	10
7	90 14 10 060 00 90	Dichtung	1	2
8	09 29 06 020-06	Spindel	1	-
Ersatzteil nicht mehr bestellbar, bitte bestellen Sie den Nachfolgeartikel				
9	90 14 15 020 03 90	Ring	1	2
10	90 23 30 023 00 90	Mutter	1	2
11	09 30 01 107 90	Huelse	1	2
12	90 90 03 304 10 90	Umstellung	1	2