



36 200 710



- Inversor giratorio
- Roseta 60 x 78 mm

	Cromo	36 200 710-00
	Platino cepillado	36 200 710-06

Complementos necesarios



- Inversor empotrado de dos vías - 35 202 970 90**
- Profundidad de montaje mín. 85 mm
 - Profundidad de montaje máx. 155 mm

36 200 710

mm [inches]



Diagrama de flujo



Certificado

LGA_38379.

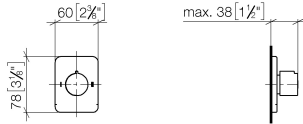
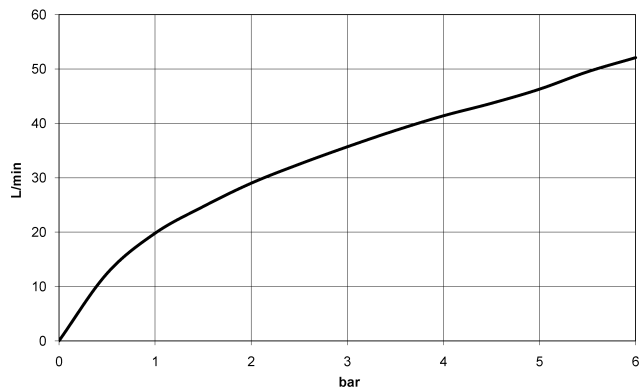
WRAS_2307045.

36 200 710

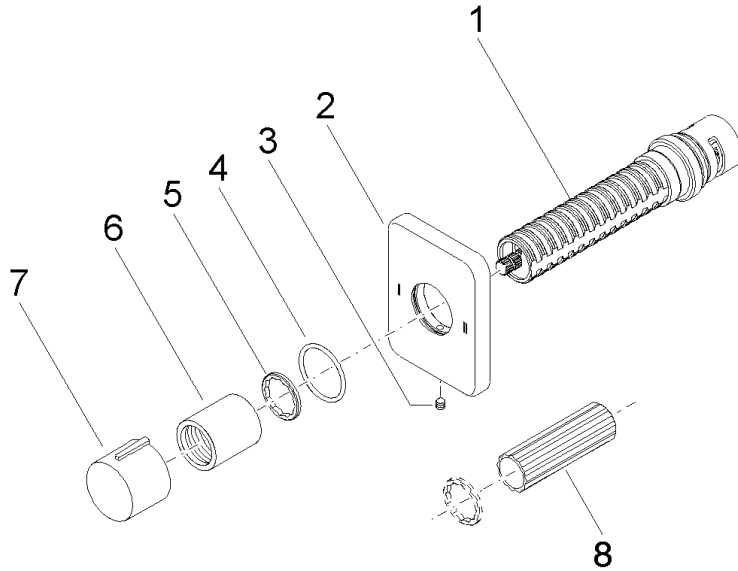

Lista de piezas de recambios

N°	Número de artículo	Denominación	Cantidad de montaje	Plazo de entrega
1	90 90 03 304 10 90	inversor	1	2
2	09 27 71 114-00	roseta	1	60
3	90 31 11 007 00 90	varilla	1	2
4	90 14 10 063 00 90	sello	1	2
5	09 16 01 025 90	anillo	1	2
6	09 21 02 070-00	funda	1	10
7	09 20 97 030-00	manilla	1	10
8	90 30 09 010 00 90	llave	1	2