

28 450 980



- sortie douche 3/8"
- rosace 60 x 60 mm
- raccord 1/2"

Avec sécurité anti-retour.

S'adapte aux gammes suivantes : IMO,
MEM, CL.1, CYO

| | | |
|---|-----------------------------|---------------|
|  | Platine | 28 450 980-08 |
|  | Chrome | 28 450 980-00 |
|  | Platine brossé | 28 450 980-06 |
|  | Laiton (Or 23cts) | 28 450 980-09 |
|  | Dark Chrome | 28 450 980-19 |
|  | Or clair brossé | 28 450 980-27 |
|  | Laiton brossé (Or 23cts) | 28 450 980-28 |
|  | Noir mat | 28 450 980-33 |
|  | Champagne brossé (Or 22cts) | 28 450 980-46 |
|  | Champagne (Or 22cts) | 28 450 980-47 |
|  | Chrome brossé | 28 450 980-93 |
|  | Dark Platinum brossé | 28 450 980-99 |

Accessoires recommandés



- Coude mural à encastrer -** 35 085 970 90
- profondeur de montage max. 163 mm
 - profondeur de montage mini. 90 mm

28 450 980

mm [inches]



Diagramme de débit



Certificats

IAPMO_4976 (5). Belgaqua_22_280_2 WRAS_2310091. WRAS_1807022.
7_7.

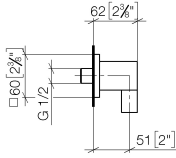
28 450 980

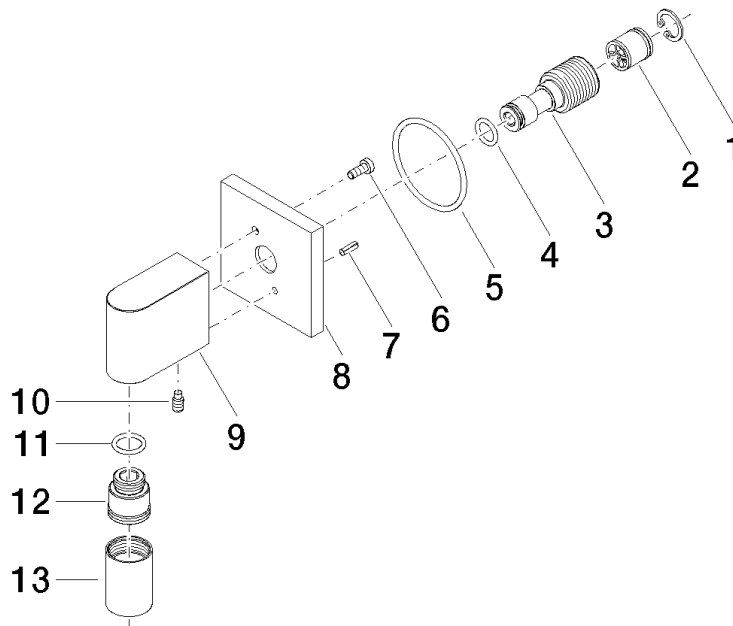

Liste des pièces de rechange

| N° | Article Numéro | Désignation | Fréquence de montage | Délai de livraison |
|----|--------------------|---------------|----------------------|--------------------|
| 1 | 09 16 01 014 90 | anneau | 1 | 2 |
| 2 | 90 23 01 141 00 90 | anti-retour | 1 | 2 |
| 3 | 09 24 03 116 20 90 | raccord à vis | 1 | 2 |
| 4 | 09 14 10 008 90 | joint | 1 | 2 |
| 5 | 09 14 10 142 90 | joint | 1 | 2 |
| 6 | 09 30 30 054 90 | vis | 1 | 2 |
| 7 | 09 31 11 026 90 | tige | 1 | 2 |
| 8 | 09 27 82 006-08 | rosace | 1 | 40 |
| 9 | 09 11 03 046-08 | raccord | 1 | 40 |
| 10 | 09 31 11 005 90 | tige | 1 | 2 |
| 11 | 90 14 10 077 00 90 | joint | 1 | 2 |
| 12 | 09 24 03 107 20 90 | raccord à vis | 1 | 2 |
| 13 | 90 21 02 069 00-08 | hotte | 1 | 40 |