



Concealed wall mounting -

35 050 970 90



- red brass, lead-free
- 2x female thread 1/2" connections
- dust cover
- anti-water packing
- soundproofing
- WRAS 2101043, 2011027

Recommended miscellaneous

Extension 25 mm -

12 055 970 90



Recommended miscellaneous

Rosette - Chrome
●with angular rosette

12 720 980-00



Recommended miscellaneous

Rosette - Chrome
●with round rosette

12 720 660-00



Concealed wall mounting -

35 050 970 90

mm [inches]

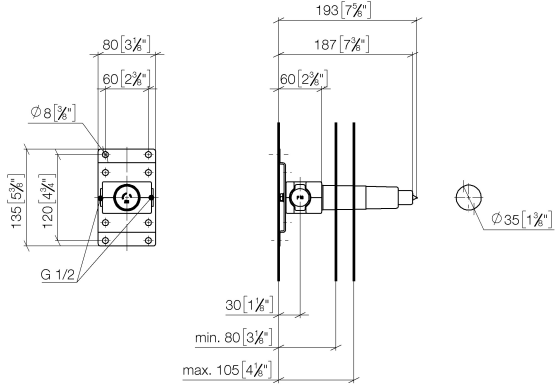

Flow rate chart

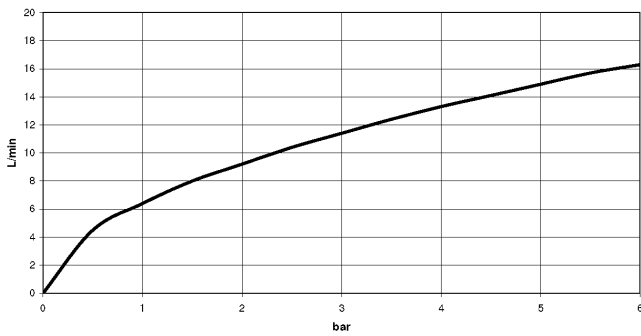

Codes & Standards

EN 817

Scottish Water
Byelaws

UK Water Supply
Regulations



Concealed wall mounting -

35 050 970 90

Certificates

DVGW_DW-
6512DN0

WRAS_2011

WRAS_2101

Concealed wall mounting -

35 050 970 90

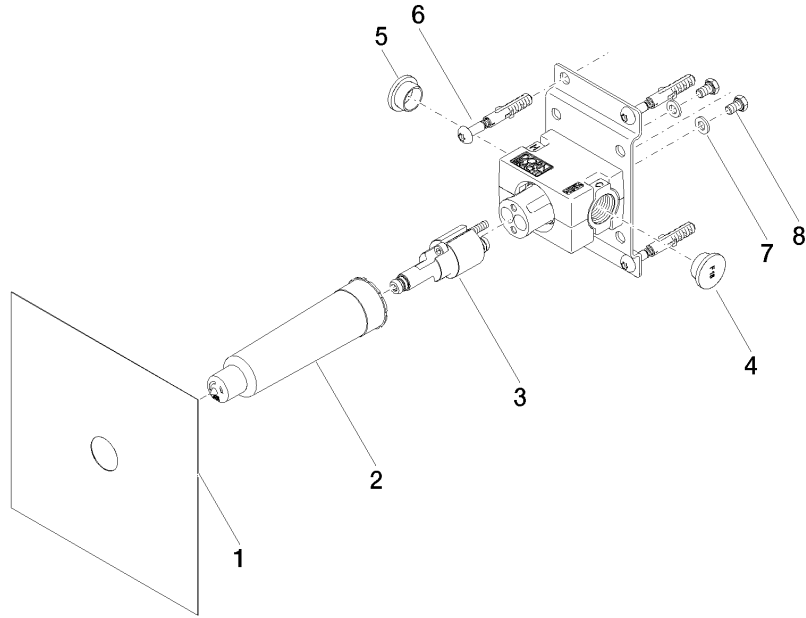



Concealed wall mounting -

35 050 970 90

Spare parts list

No.	Item Number	Name	Quantity used	Delivery time
	04 14 03 072 01 90	gasket kit	11	2