



Wall valve 1/2" -

35 607 970 90



- red brass, lead-free
- female thread 1/2" connection
- 1x female thread 1/2" outlet
- dust cover
- anti-water packing
- soundproofing
- suitable for xGRID (when using installation track + 12 mm recess depth)
- WRAS 2010066

Required miscellaneous

Leak protection 1/2" -

12 010 970 90





Wall valve 1/2" -

35 607 970 90

mm [inches]

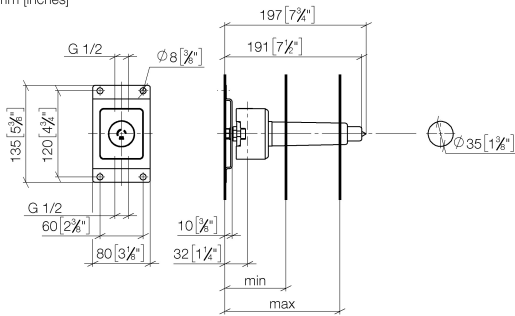

	min	max
CL_2	73 [2 7/8"]	146 [5 3/4"]
Madison	75 [3"]	145 [5 3/4"]
Madison Flair	75 [3"]	145 [5 3/4"]
Lulu	75 [3"]	145 [5 3/4"]
Vaia	75 [3"]	145 [5 3/4"]
Symetrics	75 [3"]	145 [5 3/4"]
Tara	85 [3 3/8"]	145 [5 3/4"]
Deque	85 [3 3/8"]	145 [5 3/4"]
CL_1	105 [4 1/8"]	150 [5 7/8"]
Mem	105 [4 1/8"]	150 [5 7/8"]

Flow rate chart

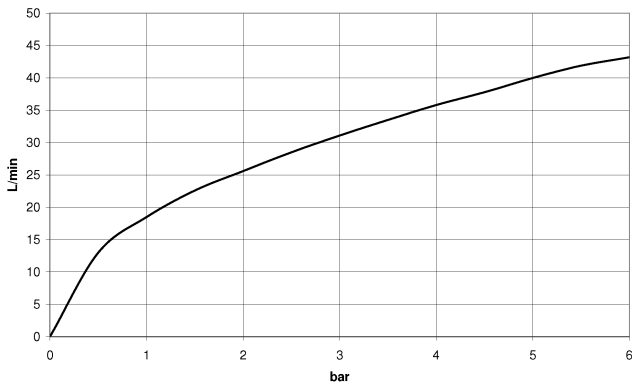

Codes & Standards

EN 200

Scottish Water
Byelaws

UK Water Supply
Regulations



Wall valve 1/2" -

35 607 970 90

Certificates

DVGW_DW-
6501DN0

WRAS_2010

Wall valve 1/2" -

35 607 970 90

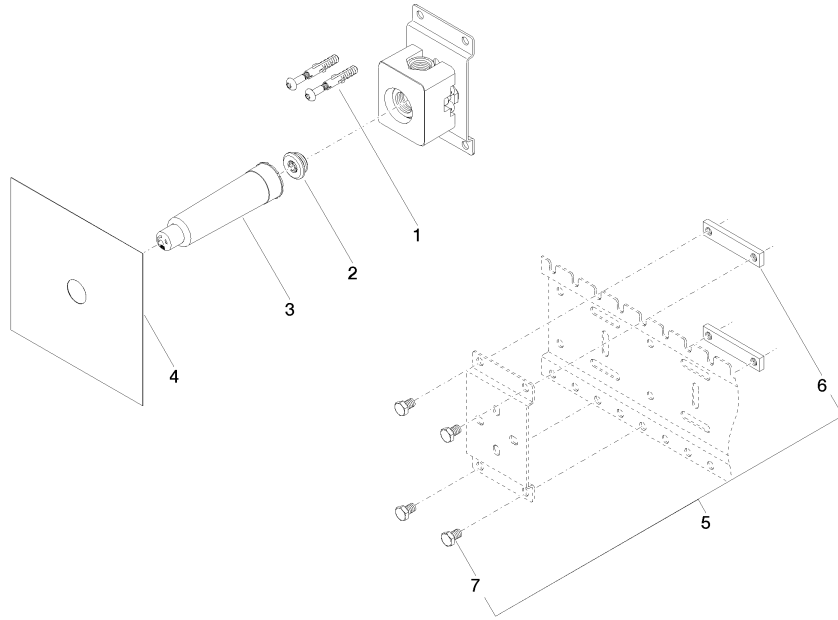



Wall valve 1/2" -

35 607 970 90

Spare parts list

No.	Item Number	Name	Quantity used	Delivery time
	04 30 31 024 01 90	fixing set	12	2